



提煉寶  
SPEEDY REFINE COOKER

PC8320

ZH-HK 說明書

EN Instruction Manual



**Primada** 實康達®

<b>ZH-HK</b>	<b>說明書</b> .....	2
<b>EN</b>	<b>Instruction Manual</b> .....	18

---

感謝您選購寶康達產品 —— 提煉寶！希望您使用愉快，我們相信這款全新提煉鍋將幫助您烹調更快速方便，讓您重新感受到烹飪的樂趣及擁有不一樣的美食滋味。

使用中如果遇到任何問題，請聯絡我們的售後服務中心，將有專業人員為您解答問題。

如欲更多產品資訊：[www.primada.com.hk](http://www.primada.com.hk)

本資料產品以實物為準，原廠保留產品更新的權利，如有變動，恕不另行通知。

**感謝您的選擇！**

## 目錄

---

1. 安全注意事項 .....	2
2. 產品組成 .....	3
2.1 包裝隨附物件 .....	3
2.2 技術參數 .....	3
2.3 組件名稱 .....	4
3. 電器原理圖 .....	5
4. 產品使用 .....	6
4.1 使用前須知 .....	6
4.2 操作說明 .....	7
4.3 顯示器與指示燈指引 .....	12
4.4 提醒 .....	14
4.5 烹飪參考 .....	14
5. 清洗與保養 .....	15
6. 疑難排解 .....	17

# 1. 安全注意事項

使用產品前請仔細閱讀此說明書。  
請保管好此說明書。

使用產品時，請保持一貫的警惕性，遵循以下事項：

1. 一般電器產品並不是為體質、感覺或智力有障礙人士（包括小孩），或缺乏經驗及知識者使用，除非他們曾經接受負責安全人士的監督或指示。
2. 請小心看管小孩，以確保他們不會把此電器當作玩具。
3. 禁止將產品放在易燃物品及潮濕環境中使用。
4. 加入內煲的食物和水的高度必須按產品使用內操作說明的第2點規定。
5. 不能損傷密封圈，不能用其他膠圈取代，不能使用張力圈來增加密封。
6. 不能用手或其他工具強行扭動煲蓋內側鋼圈。如果鋼圈脫落煲蓋，請停止使用，更換煲蓋。
7. 防堵罩應經常清洗，保持清潔。
8. 浮子閥未落下時，切勿強行開蓋。
9. 限壓放氣閥上不得添加任何重物或以其他物體代替。
10. 內煲底部與發熱盤接觸面應保持清潔。內煲不能放在其他熱源上燒煮，不能用其他容器取代內煲。
11. 內煲碰撞變形後，請勿使用，否則會造成漏氣。
12. 內煲塗有不粘塗層，為防止劃傷內壁塗層，請使用木質或塑料飯杓。
13. 保溫最長時間24小時，使用時宜不超過6小時，以免影響烹飪效果。
14. 在加熱烹飪過程中，發生鍋蓋周邊大量排氣，屬於非正常工作現象，此時泄壓安全裝置起了保護，請立即拔下電源插頭，停止使用，送本公司維修點檢修。
15. 在使用過程中，發生警報聲，並且顯示器顯示如下故障代碼，請停止使用。送本公司維修點檢修。

顯示器代碼	E 1	E 2	E 3	E 4
故障	傳感器斷路	傳感器短路	超溫	信號開關失靈

16. 搬移產品時，請端提手，勿提煲蓋手柄。
17. 用戶請勿自行拆卸產品，或用其他零件更換，產品僅可使用本公司的零配件。
18. 提起限壓放氣閥放氣時，請勿將手或臉靠近限壓放氣閥放氣管，工作時請勿觸摸煲蓋，以免燙傷。
19. 烹調結束後，食用前必須先將電源切斷。
20. 工作時或結束後煲蓋未達到冷卻狀態，切勿用手觸摸煲蓋，以免燙傷。
21. 禁止用抹布堵塞煲蓋與外煲扣合處周邊，以免影響安全性。
22. 當煲內還有氣壓時，不能強行開蓋，以防止意外。
23. 提起煲蓋時，請小心由限壓放氣閥槽位流出的熱水燙手。

## 2. 產品組成

### 2.1 包裝隨附物件



PC8320



飯杓



量杯



集水盒



電源線



說明書



食譜



產品保用證

### 2.2 技術參數

型號	PC8320		
工作電壓	220-240V AC	頻率	50Hz
額定功率	1200W		
容量	8L	口徑	24cm
工作壓力	0~70kPa	限壓壓力	90kPa
保溫溫度	60~80°C	預約定時	1~24小時

\* 因產品持續改善，原廠保留產品更新的權利，如有變動，恕不另行通知。

## 2. 產品組成

### 2.3 組件名稱

#### 主機

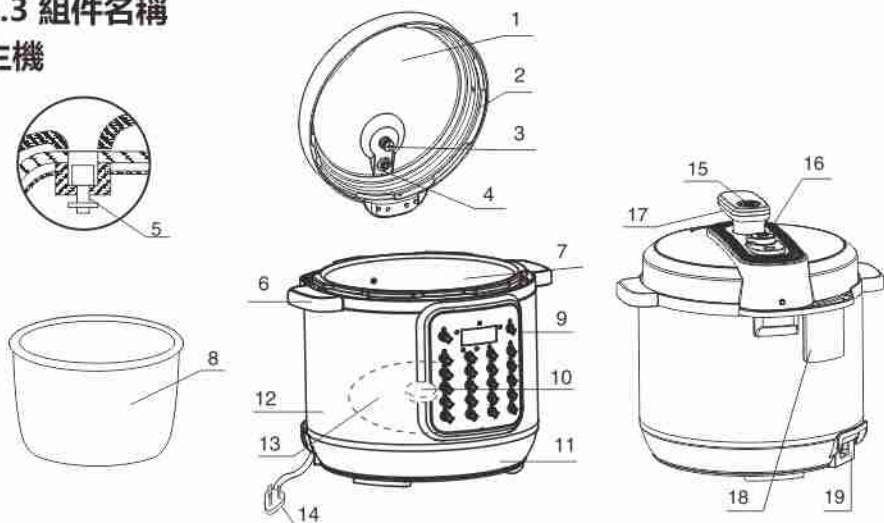

- |         |         |           |
|---------|---------|-----------|
| 1. 煲蓋   | 8. 內煲   | 15. 排氣按鈕  |
| 2. 密封圈  | 9. 控制面板 | 16. 限壓放氣閥 |
| 3. 防堵螺母 | 10. 傳感器 | 17. 手柄    |
| 4. 浮子閥  | 11. 底座  | 18. 集水盒   |
| 5. 浮子   | 12. 外殼  | 19. 插座    |
| 6. 上座   | 13. 發熱盤 |           |
| 7. 外煲   | 14. 電源線 |           |

#### 控制面板

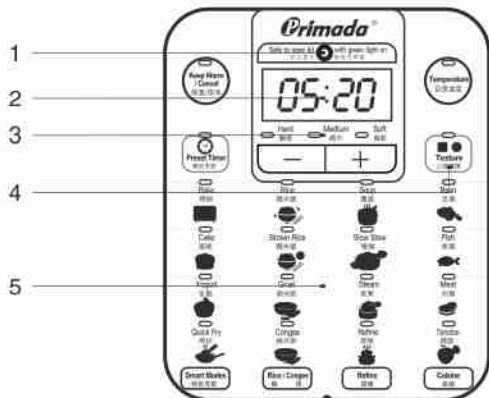

1. 開蓋指示燈
2. 顯示器
3. 口感指示燈
4. 口感選擇按鍵
5. 菜單按鍵

### 3. 電器原理圖

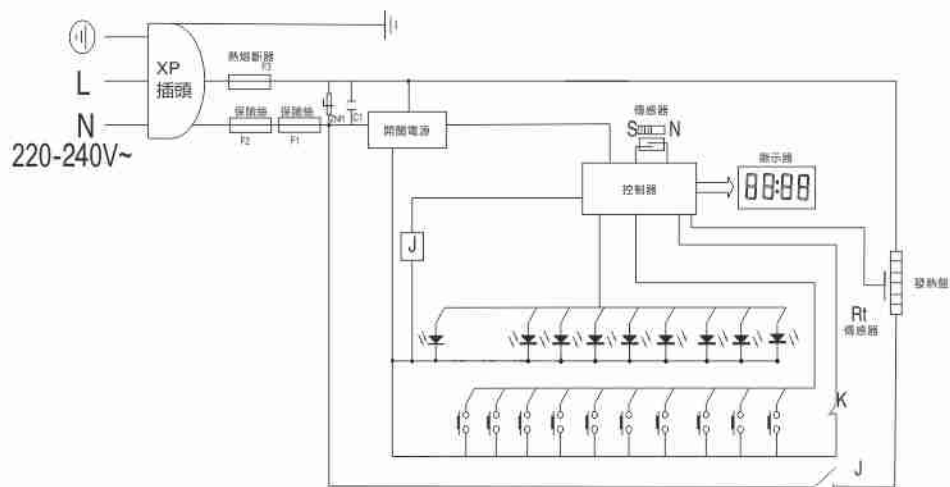

## 4. 產品使用

### 4.1 使用前須知

#### ■ 首次使用

- 將所有包裝拆除。
- 取出所有隨附物件。
- 將集水盒安裝在煲體上。
- 用軟布清洗與食物直接接觸的所有物件。



#### ■ 日常使用

- 檢查密封圈是否正確安裝在鍋蓋上，密封圈卡槽必須卡在鋼圈上。
- 檢查排氣孔、浮子閥孔是否暢通，如有堵塞，必須清洗乾淨。

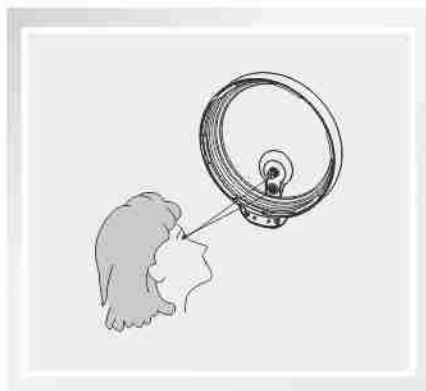



## 4. 產品使用

### 4.2 操作說明

#### ■ 開蓋

- 用手握緊煲蓋手柄，逆時針方向旋轉煲蓋至旋不動，向上提起即可打開煲蓋。



#### ■ 取出內煲，將食物和水放入內煲中。

- 食物和水不得超過內煲高度的 $\frac{4}{5}$ 。
- 水中易膨脹食物不得超過內煲高度的 $\frac{3}{5}$ 。
- 食物和水不得少於內煲高度的 $\frac{1}{5}$ 。

\* 8L最大煮米量是16杯。1杯米配一杯水，用戶可根據不同米質及個人口味適當調整水量。

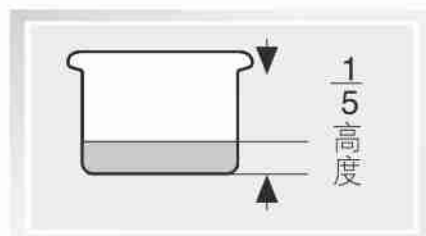
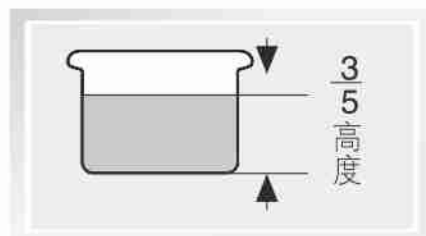
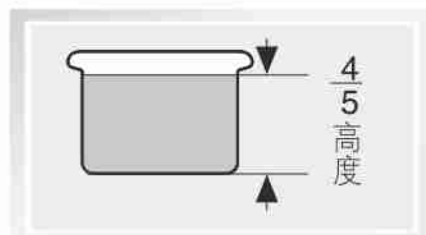

## 4. 產品使用

### ■ 將內煲放入外煲內。

- 放入前，先把內煲及發熱盤抹乾淨，外煲內及發熱盤表面不得放入雜物。
- 放入後，左右輕輕旋轉內煲，保持內煲與發熱盤接觸良好。



### ■ 合蓋

- 檢查密封圈是否已放入煲蓋內側鋼圈上。
- 用手左右旋轉一下密封圈，使它自由均勻放置在鋼圈上。
- 手握煲蓋手柄，將煲蓋後端對準集水盒方向，往下蓋在煲體上，然後順時針旋轉煲蓋至旋不動，並聽到“咔嚓”扣合聲。

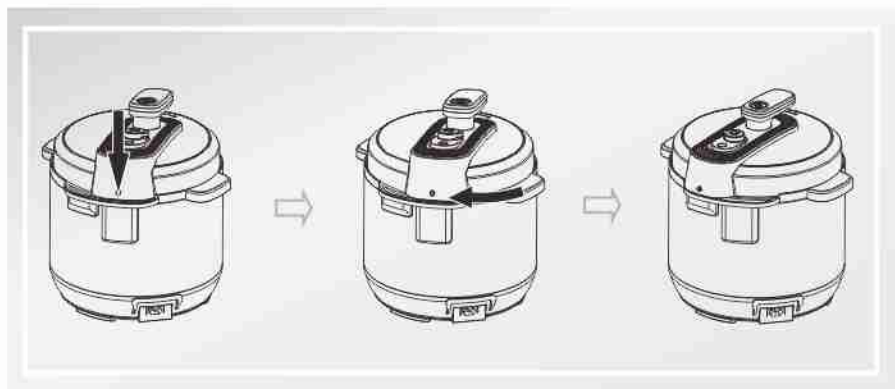

## 4. 產品使用

- 放置好限壓放氣閥，根據圖示放置，並檢查浮子是否落下（未加熱工作前浮子閥是落下的）。

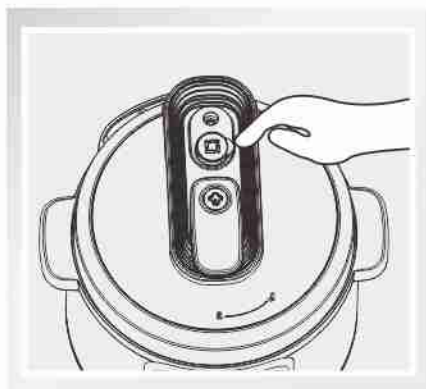

- 將電源線線尾插入插座，電源線插頭插入電源插座。

- 接通電源，進入待機狀態，顯示器顯示0000。



## 4. 產品使用

### ■ 預約定時

設定預約定時時間（如果不要預約定時，省去此步驟）。按一下“預約烹飪”鍵，再按“+”“-”鍵設定預約時間。可設定預約定時最長24小時（預約定時指設定多少時間後，開始加熱工作）。

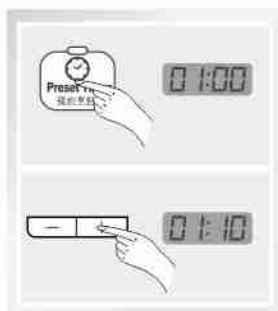

### ■ 根據烹飪食物選擇菜單鍵。

- 選擇控制面板上的菜單鍵，則按一下所選菜單鍵（例：煮飯按一下“精米飯”鍵），所選擇菜單工作指示燈亮，開始工作。
- 如需調整口感，以下功能：精米飯、糙米飯、潮州粥、綿米粥、濃湯、蒸煮、豆類、魚類、肉類、蹄筋，按菜單鍵後，可以通過按“口感選擇”鍵選擇偏軟、偏硬或適中的口感，按鍵後口感指示燈會指示當前口感類別。
- 如需調整烹飪時間，以下功能：烤焗、乳酪、慢燉、提煉、自選溫度，按菜單鍵后，可以通過按“+”“-”鍵設定為用戶所需的時間，設定后等待6秒即自動啟動。
- 選擇“自選溫度”功能，顯示器顯示默認工作溫度和時間為40攝氏度和10分鐘，可以通過再按“自選溫度”鍵設定用戶所需的工作溫度，也可以通過按“+”“-”鍵設定為用戶所需的時間，設定後等待6秒即自動啟動。



## 4. 產品使用

### ■ 當顯示END時，可以開蓋取出食物，方法如下：

- 方法一：按一下“保溫/取消”鍵，取消保溫。按住排氣按鈕排氣，直至浮子閘落下。
- 方法二：等待自然冷卻，綠色開蓋指示燈亮。

\* 如果煮流質食物（粥類、粘性液），當顯示END時，不能用方法一，只能用方法二，否則粘性液會在排氣管噴出。可用濕巾蓋在煲蓋上加快冷卻速度。

### ■ 拔下電源插頭

### ■ 開蓋

- 手握煲蓋手柄，逆時針旋轉煲蓋至旋不動，向上提起鍋蓋，即可取用。



## 4. 產品使用

### 4.3 顯示器與指示燈指引

#### 顯示器

- 選擇普通菜單，菜單指示燈長亮，顯示器顯示：C+滾動圖案，表示開始加熱。
- 如果選擇可調整時間的菜單，菜單指示燈閃爍，顯示器顯示時間並閃爍，時間設定後，繼續閃爍6秒，顯示器轉為顯示：C+滾動圖案，菜單指示燈長亮，表示開始加熱。
- 如果選擇“自選溫度”菜單，菜單指示燈閃爍，顯示器顯示時間並閃爍，時間設定後，繼續閃爍6秒，顯示器停止閃爍，菜單指示燈長亮，表示開始加熱。
- 如果設定了預約定時，定時燈亮，顯示器顯示預約時間，選擇菜單後，菜單鍵指示燈長亮，表示該菜單已選定，此時轉為顯示預約時間，並開始倒數。倒數結束後，進入上述菜單的加熱顯示狀態。
- 加熱一段時間後，煲內壓力達到工作壓力或者溫度達到工作溫度時，顯示器顯示“P+滾動圖案”或者“P+時間”，乳酪、慢燉、提煉、自選溫度功能會顯示時間。
- 工作時間完成後，顯示器顯示END，進入保溫狀態，保溫燈長亮，此時烹飪已結束。



## 4. 產品使用

### 保溫/取消和開蓋指示燈

- 工作時間完成後，自動轉入保溫狀態，最長可以保溫24小時，保溫中在按“保溫/取消”鍵，取消保溫。
- 在設定參數或在工作過程中，按一下“保溫/取消”鍵，取消設定及工作狀態。
- 在待機狀態下，按一下“保溫/取消”鍵，保溫燈長亮，進入保溫狀態，再按“保溫/取消”鍵，取消保溫。
- 在工作完成後，進入保溫狀態，煲內如果有壓力，不能直接開蓋，待煲內壓力下降到無壓力狀態，綠色開蓋指示燈亮，表示可以安全開蓋。



## 4. 產品使用

### 4.4 提醒

- 針對以下菜單：精米飯、糙米飯、潮州粥、綿米粥、濃湯、蒸煮、豆類、魚類、肉類、蹄筋和提煉，產品設有煲蓋檢測保護。
- 在待機狀態下，如煲蓋沒有鎖到位，按下菜單，產品會蜂鳴三聲提示煲蓋沒有鎖好，轉回待機。
- 在工作過程中，如煲蓋被解鎖/打開，產品會蜂鳴一聲提示煲蓋打開，並停止加熱，直至煲蓋鎖到位，繼續當前工作。

### 4.5 烹飪參考

菜單	默認時間	偏硬	偏軟	可調時間範圍
烤焗	30分鐘	/	/	1-99分鐘
蛋糕	30分鐘	/	/	/
乳酪	8小時	/	/	0.5小時-12小時
煎炒	30分鐘	/	/	/
精米飯	12分鐘	10分鐘	17分鐘	/
糙米飯	15分鐘	12分鐘	20分鐘	/
潮州粥	15分鐘	12分鐘	20分鐘	/
綿米粥	25分鐘	22分鐘	30分鐘	/
濃湯	30分鐘	27分鐘	35分鐘	/
慢燉	1小時	/	/	0.5小時-8小時
蒸煮	10分鐘	7分鐘	15分鐘	/
提煉	1小時	/	/	1-6小時
豆類	30分鐘	27分鐘	35分鐘	/
魚類	5分鐘	3分鐘	7分鐘	/
肉類	10分鐘	7分鐘	13分鐘	/
蹄筋	22分鐘	19分鐘	25分鐘	/
自選溫度	10分鐘	/	/	1-99分鐘



## 5. 清洗與保養

### 清潔方法

- 清洗前請先拔下電源插頭。
- 用抹布將煲體擦乾淨。禁止將煲體浸入水中清洗或用水噴淋。
- 將集水盒拆下來清洗，用濕巾擦乾淨上座。
- 用水清洗煲蓋內側，包括：密封圈、限壓放氣閥、防堵螺母、放氣管、浮子閥，然後用抹布擦乾淨。
- 用海綿或非金屬軟刷清洗內煲，然後用抹布擦乾。
- 用細刷子清洗限壓放氣閥閥座。

### 鍋蓋清洗方法

- 將煲蓋旋開、取下，將限壓放氣閥向上取出，用清水清洗。

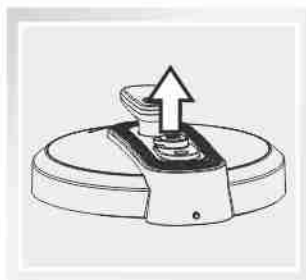

- 將防堵螺母逆時針旋轉拆下，用清水清洗，清洗完安裝到原位置



## 5. 清洗與保養

- 將密封圈從鍋蓋鋼圈上輕輕拉出。清洗後，將密封圈裝在鋼圈上。



- 檢查並清洗放氣管和浮子閥。

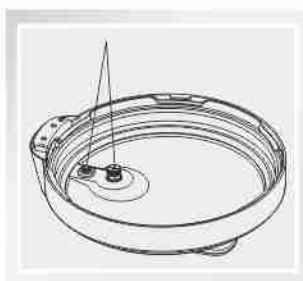

- 確保所有部件都裝回鍋蓋上，再使用。



## 6. 疑難排解

產品使用過程中，若遇以下情況可對照查詢，自主解決。

序 號	故障情況	可能原因	解決方法
1	合蓋困難	密封圈未放置好	放好密封圈
		浮子閥卡住推杆	用手輕推推杆
2	開蓋困難	放氣後浮子閥未落下	用手輕拍煲邊數次令浮子閥落下
3	煲蓋漏氣	未放上密封圈	放上密封圈
		密封圈粘有食物渣子	清潔密封圈
		密封圈磨損	更換密封圈
		未合好蓋	按規定合蓋
4	浮子閥漏氣	浮子閥密封圈粘有食物渣子	清潔浮子閥密封圈
		浮子閥密封圈磨損	更換浮子閥密封圈
5	浮子閥不能上升	煲內食物和水過少	按規定放食物和水
		煲蓋或限壓放氣閥漏氣	送維修點檢查

Congratulations on the purchase of your Primada Speedy Refine Cooker! We hope it brings you many years of satisfaction. We trust the purchase of your new cooker will help you for fast/convenient cooking. Let you enjoy cooking and delicious foods.

Should you encounter situations that have not been properly addressed in this Instruction Manual, please contact our Customer Service Center where a technician can address your specific problem or question.

For more information, please visit the official website: [www.primada.com.hk](http://www.primada.com.hk)

The Company reserves the right to make technological and/or design changes to this product for continuous improvement.

***Thank you for choosing!***

## Contents

---

<b>1. Important Safety Instructions</b> .....	18
<b>2. Package Contents and Technical Specifications</b> .....	19
2.1 Package Contents .....	19
2.2 Technical Specifications .....	19
2.3 Product Diagram .....	20
<b>3. Schematic Diagram</b> .....	21
<b>4. Operating</b> .....	22
4.1 Before use .....	22
4.2 Operation .....	23
4.3 Screen and Indicator Guide .....	28
4.4 Reminder .....	30
4.5 Cooking Reference .....	30
<b>5. Cleaning and Maintenance</b> .....	31
<b>6. Troubleshooting</b> .....	33

# 1. Important Safety Instructions

**READ ALL INSTRUCTIONS BEFORE USING THIS APPLIANCE.  
PLEASE KEEP THE INSTRUCTION MANUAL**

**When using our product, basic precautions should always be followed, including the following:**

1. This appliance is not intended for use by persons (including children) with reduced physical, sensory or mental capabilities, or lack of experience and knowledge, unless they have been given supervision or instruction concerning use of the appliance by a person responsible for their safety.
2. Children should be supervised to ensure that they do not play with the appliance.
3. DO NOT place the product near flammable materials or use it in humid environment.
4. The amount of food and water to be put into the Inner Pot MUST be strictly according to the step 2 in the section "Operation".
5. DO NOT damage the Seal Belt and DO NOT replace it with any other rubber belt or tensile belt.
6. DO NOT move the Steel Ring in the Lid with any tools or external forces. If the Steel Ring breaks off from the Lid, please stop using the cooker and replace the Lid with a new one.
7. Clean the Filter regularly to keep the cooker clean.
8. DO NOT open the Lid with external force when the Floating Valve has not sunk.
9. NEVER add any additional weight on the Pressure Limiting Valve or replace the Pressure Limiting Valve with other object.
10. The surface of contact between the Inner Pot and the Electronics Heater should always in clean condition. DO NOT use the Inner Pot to cook by using other heating sources. DO NOT replace the Inner Pot with other container.
11. Please do not use the damaged Pot, otherwise will cause air leaking.
12. The Inner Pot consist of a Non-stick layer surface. To avoid scratching the Non-stick surface, please use wooden or plastic ladle or spoon.
13. Food should not be kept warm for more than 6 hours in order to preserve the Natural Nutrients, Texture and Tastiness of the foods.
14. If steam is released around the Lid during the cooking process, please unplug the power supply immediately, and send the product back to our company for repair. This is an abnormal situation because the Pressure Discharging Device has been activated and this indicates that the Pressure Limiting Device is malfunction.
15. If there is any malfunction of the cooker during the cooking process, please stop using the device and send it back to the workshop for checking and repairing.

Indicator Code	E 1	E 2	E 3	E 4
Problems/Causes	Open Circuit of the sensor	Short Circuit of the sensor	Overheating	Signal switch Malfunction

16. When moving the product, please use the Side Handle and avoid using the Lid Handle.
17. DO NOT disassembly the product, or replace its parts with others which are not produced by our company. The product can only use the spare parts produced by our company.
18. When discharging, keep your face or hand away from the relief pipe and from the lid during operation to avoid scald.
19. Unplug appliance from main electricity supply before taking food.
20. Don't touch the lid during cooking procedure or in heating status.
21. Never block the periphery of the clamping position to ensure safety.
22. Never attempt to uncover the cooker when floating valve is flopping or hercis pressure inside.
23. Please mind of flowing hot water from the pressure limiting valve when opening the lid.

## 2. Package Contents and Technical Specifications

### 2.1 Package Contents



PC8320



Spoon



Cup



Water Storage



Power Cable



IM



Recipe



Warranty

### 2.2 Technical Specifications

<b>Model</b>	PC8320		
<b>Voltage</b>	220-240V AC	<b>Frequency</b>	50Hz
<b>Power</b>	1200W		
<b>Capacity</b>	8L	<b>Diameter</b>	24cm
<b>Working Pressure</b>	0~70kPa	<b>Maximum Pressure</b>	90kPa
<b>Keep Warm Temperature</b>	60~80°C	<b>Preset Timer</b>	1~24Hours

\*Package Contents and Technical and design specifications may be changed in the course of continuous product improvement.

## 2. Package Contents and Technical Specifications

### 2.3 Product Diagram Main Unit

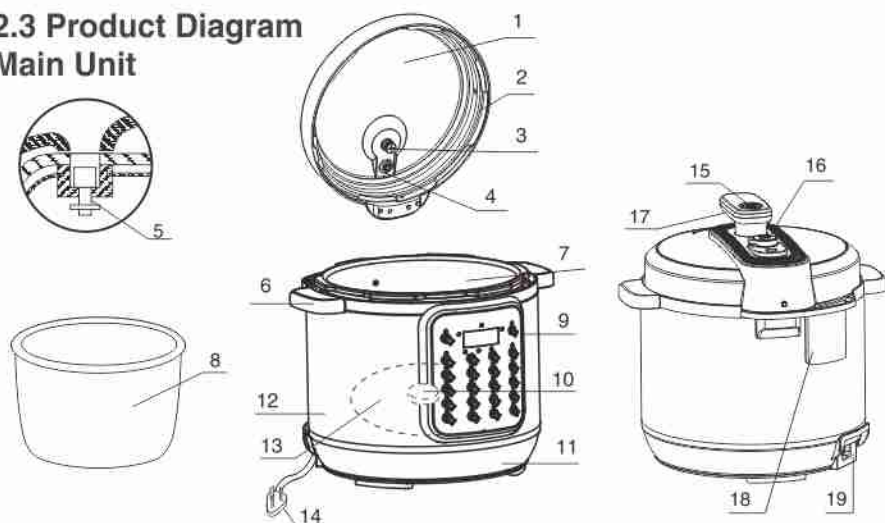

- |                   |                       |                             |
|-------------------|-----------------------|-----------------------------|
| 1. Lid            | 8. Inner Pot          | 15. Exhausting Button       |
| 2. Seal Belt      | 9. Control Panel      | 16. Pressure Limiting Valve |
| 3. Filter         | 10. Sensor            | 17. Lid Handle              |
| 4. Floating Valve | 11. Lower Body        | 18. Water Storage           |
| 5. Floater        | 12. Housing           | 19. Socket                  |
| 6. Upper Body     | 13. Electronic Heater |                             |
| 7. Outer Pot      | 14. Power Cable       |                             |

### Control Panel

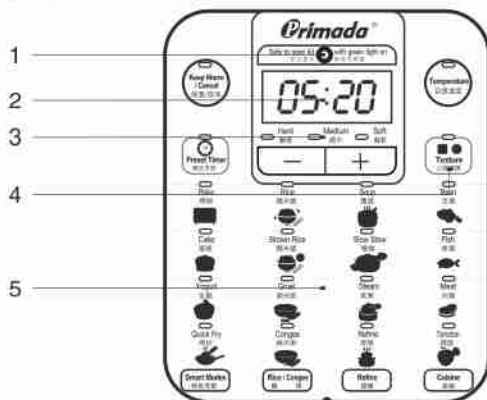

1. Lid-opening Indicator
2. Screen
3. Indicator of Texture
4. Button of Texture
5. Buttons of Menu



### 3. Schematic Diagram

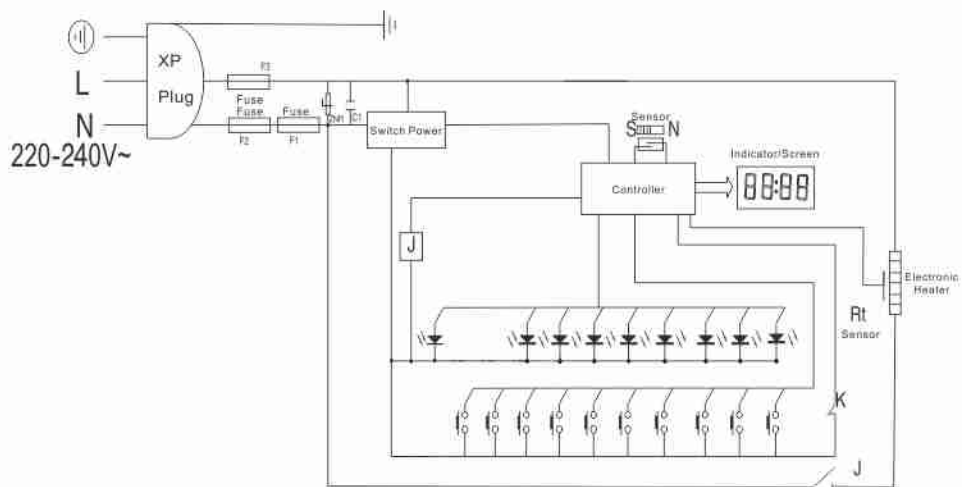

## 4. Operating

### 4.1 Before use

#### ■ First time Use

- Dismantle the packaging.
- Take out all package contents.
- Fix the Water Storage on the cooker.
- Clean all food contact components by soft cloth.



#### ■ Daily Use

- Make sure that the Seal Belt is fitted onto the inner part of the Lid.
- Check the Exhausting hole, Floating Valve hole, if blocking, must clean up first.

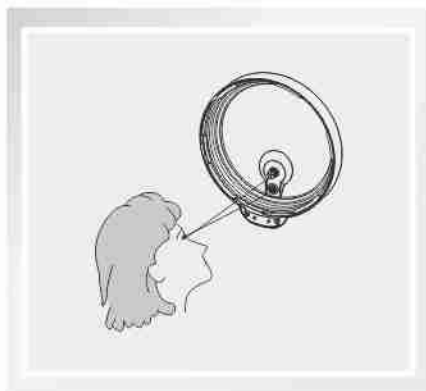
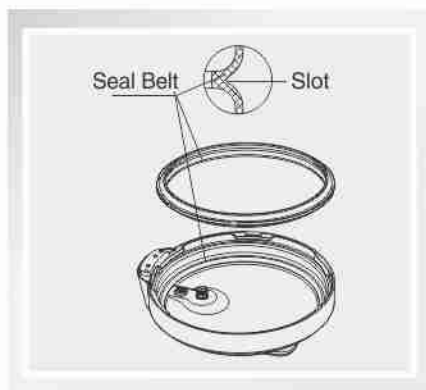

## 4. Operating

### 4.2 Operation

#### ■ Open the Lid

- Hold the Handle and turn it in anticlockwise direction until reach the end position. Then, lift the Lid upward.

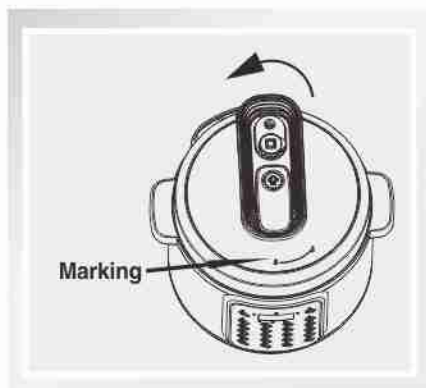

#### ■ Take the Inner Pot and place food and water into the Inner Pot.

- The amount of water and food shall not exceed  $\frac{4}{5}$  of the height of Inner Pot.
- For food that will swell in water, the level should not exceed  $\frac{3}{5}$  of the Inner Pot.
- The minimum allowable level would be  $\frac{1}{5}$  of the Inner Pot.

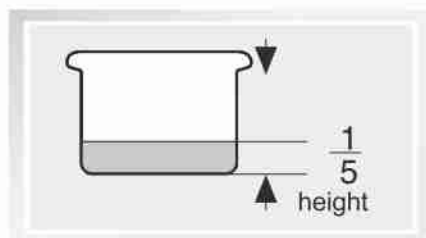
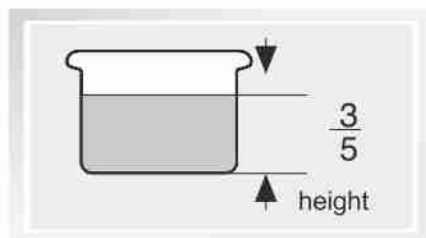
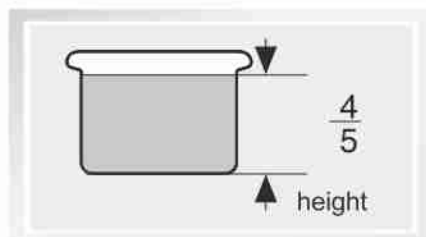

\* In the case of cooking rice, the maximum amount of rice allowed for 8L are 16 cups. Normally one cup of rice will need one cup of water for cooking rice. But this can be adjusted according to the taste of individuals.

## 4. Operating

### ■ Putting the Inner Pot into the Outer Pot

- Dry clean the outer surface of the Inner Pot and the Electronics Heater before putting the Inner Pot into the Outer Pot. Do not place any material on the surface of the Electronics Heater and inside the Outer Pot.
- After that, turn the Inner Pot left and right to ensure a firm contact between the Inner Pot and the Electronic Heater.



### ■ Close the Lid

- Make sure that the Seal Belt is fitted onto the inner part of the Lid.
- Move the Seal Belt inside the Lid to ensure that it is evenly fitted into the track.
- Hold the Lid's Handle and make the backside of Lid toward to the direction of Water Storage, put downward the Lid onto the body. Then, turn it in clockwise direction unit reach the end position, and a clamping sound is heard.

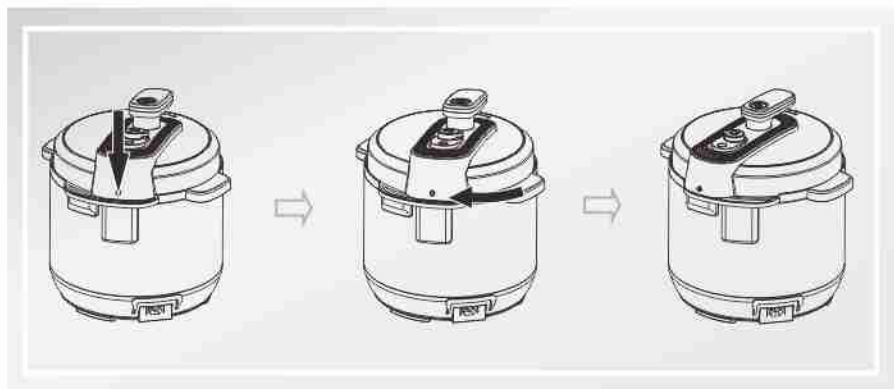

## 4. Operating

- According to the Figure on the right, place well the Pressure Limiting Valve, and ensure that the Floater sinks (The Floating Valve sinks before the heating process).

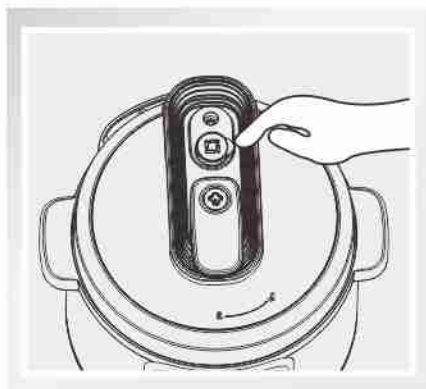

- Connect the end of Power cord into the socket of cooker, insert the plug to the power outlet.
- Turn on the power supply, the cooker will be on standby mode and the LED Screen displays 0000.



## 4. Operating

### ■ Preset Timer

Set the Preset Timer (If Preset Timer is not required, skip this step). Press "Timer" button, then press "+" "-" button to adjust preset time. The maximum Preset Timer period is 24 hours. (The time that displays on the Screen shows how long user wants the cooker to wait before heating process starts).



### ■ Choose the menu according to different recipes.

- Press the menu button (press "rice" for rice cooking, for example), the indicator light switches on and heating process starts.
- If user want to change texture of food, the following menus: Rice, Brown Rice, Gruel, Congee, Soup, Steam, Bean, Fish, Meat, Tendon, after pressing the menu button, can select the texture of Soft, Hard and Medium by pressing "Texture" button, the indicator of texture will indicate your selection.
- If user want to change the cooking time, the following menus: Bake, Yogurt, Slow Stew, Refine, Temperature, after pressing the menu button, can adjust the cooking time by pressing "+" "-" button, the screen displays the time you setting. After time setting, wait 6 seconds, the heating process starts.
- If select "Temperature" menu, Screen displays the default cooking temperature 40°C and default cooking time 10 minutes, user can adjust cooking temperature by pressing "Temperature" button again, also can adjust the cooking time by pressing "+" "-" button, the screen displays the temperature and time you setting. After setting, wait 6 seconds, the heating process starts.

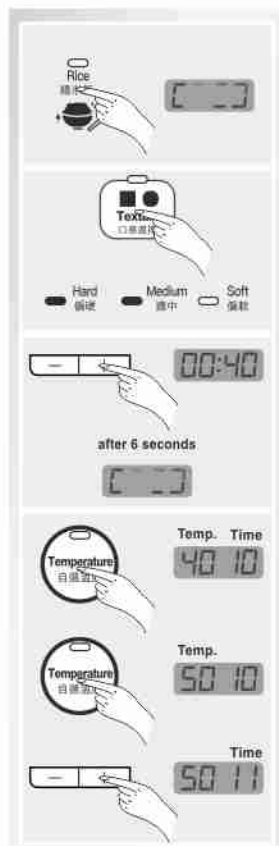

## 4. Operating

### ■ When screen displays END, lid can be opened to serve the food as follow:

- Method One: Press the Exhausting Button to release the steam, until the Floating Valve sinks.
- Method Two: Wait for cooling down itself and the Green light of Lid-opening indicator lights on.

\* For liquid food(Congee, viscous fluid), when screen displays END, never use method one, must use method two to serve the food to avoid the fluid of food to spurt out from the vent holes. Wet towel can be placed on the Lid to increase the speed of cooling down.

### ■ Unplug the Power cord.

### ■ Open the Lid

- Hold the Lid's Handle, turn it in anticlockwise direction unit reach the end position, lift upward the Lid, then the food can be served.



## 4. Operating

### 4.3 Screen and Indicator Guide

- Select the normal menus, the indicator of menu remains on, screen displays C000, and the heating process starts.



- If select menu which cooking time can be adjusted, the indicator and screen flash and screen displays time, after time setting, keep flashing for 6 seconds, screen turns to C000, the indicator light remains on, and the heating process starts.

- If select "Temperature" menu, the indicator and screen flash and screen displays time, after time setting, keep flashing for 6 seconds, screen stops flashing, the indicator light remains on, and the heating process starts.

- If Preset Time is activated, the indicator of "Preset Timer" lights will be on, screen displays preset time, after selecting menu, the indicator of menu light remains on, means this menu is activated. Then, screen turns to display preset time, and start to countdown. When the preset time countdown finishes, the screen displays the heating process as mentioned above.

- After heating for a few minutes, when the pressure or temperature inside reach the cooking level, screen displays "P000" or "P+time", following menu: Yogurt, Slow Stew, Refine, Temperature will display cooking time.



- When the cooking time finishes, screen displays END, then enter the Keep Warm mode, the indicator of Keep Warm light switches on, now the cooking process is finished.



## 4. Operating

### Keep Warm/Cancel and Lid-opening Indicator

- When the cooking time finishes, automatically turns to Keep Warm mode for up to 24 hours, during the period, press "Keep Warm/Cancel" button, the keep warm processes can be canceled.
- During the setting or cooking process, press "Keep Warm/Cancel" button, the keep warm or cooking processes can be canceled.
- Under standby mode, press "Keep Warm/Cancel" button, the indict or of Keep Warm light will be on and start keeping warm, if press this button again, it will be canceled.
- When cooking procedure ends, turns to Keep Warm mode, if pressure inside is high, the Lid can't be opened directly, waiting for the pressure drop down to no pressure, the Green light of Lid-opening indicator will be on, means the Lid can be opened safely.



## 4. Operating

### 4.4 Reminder

- For the following menus: Rice, Brown Rice, Gruel, Congee, Soup, Steam, Bean, Fish, Meat, Tendon and Refine, this cooker has lid lock detecting protection.
- Under standby mode, if the Lid is unlocked, the cooker will deliver 3 buzzes as a warning when pressing the menu, then turns back to standby mode.
- During the cooking process, if the Lid is unlocked/opened, the cooker will deliver a buzz as warning and stops heating, it will continue the cooking process when the Lid is back to locked position.

### 4.5 Cooking Reference

Menu	Default Time	Hard	Soft	Adjustable Time
<b>Bake</b>	30 Minutes	/	/	1-99 Minutes
<b>Cake</b>	30 Minutes	/	/	/
<b>Yogurt</b>	8 Hours	/	/	0.5-12 Hours
<b>Quick Fry</b>	30 Minutes	/	/	/
<b>Rice</b>	12 Minutes	10 Minutes	17 Minutes	/
<b>Brown rice</b>	15 Minutes	12 Minutes	20 Minutes	/
<b>Gruel</b>	15 Minutes	12 Minutes	20 Minutes	/
<b>Congee</b>	25 Minutes	22 Minutes	30 Minutes	/
<b>Soup</b>	30 Minutes	27 Minutes	35 Minutes	/
<b>Slow Stew</b>	1 Hour	/	/	0.5-8 Hours
<b>Steam</b>	10 Minutes	7 Minutes	15 Minutes	/
<b>Refine</b>	1 Hour	/	/	1-6 Hours
<b>Bean</b>	30 Minutes	27 Minutes	35 Minutes	/
<b>Fish</b>	5 Minutes	3 Minutes	7 Minutes	/
<b>Meat</b>	10 Minutes	7 Minutes	13 Minutes	/
<b>Tendon</b>	22 Minutes	19 Minutes	25 Minutes	/
<b>Temperature</b>	10 Minutes	/	/	1-99 Minutes

## 5. Cleaning and Maintenance

### Cleaning Methods

- Unplug the power cable prior to cleaning.
- Brush the bottom of the cooker with a cloth. Never place the cooker into water or spray water on it.
- Take off and clean the water storage and wash it with a wet towel.
- Clean the inner side of the cooker, including the sealant washer, pressure discharging valve, anti-blocking case, steam relief pipe, floating valve with water and clean it with a cloth.
- Use a sponge or nonmetal soft brush to wash the inner pot and clean it with a cloth.
- Clean the base of pressure limiting valve and water drain hole with a small brush.

### Lid Cleaning Methods

- Turn the Lid and take it out. Then, take off the Pressure Limiting Valve, clean it with water.

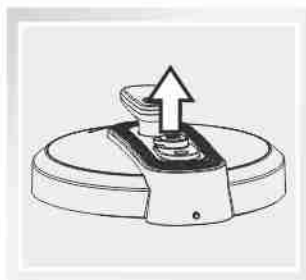

- Turn the Filter in anticlockwise to take it off, clean it with water. Then fix in the same position.



## 5. Cleaning and Maintenance

- Gently pull out the Seal Belt from the Steel Ring of the Lid. After cleaning, fix it in the Steel Ring well

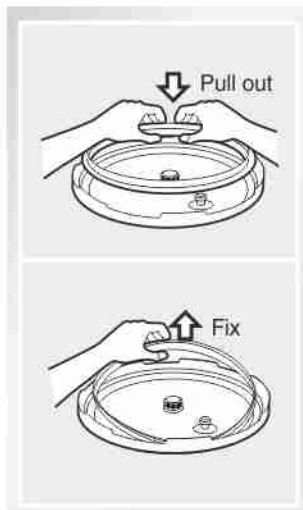

- Check and clean the Exhausting hole, Floating Valve.

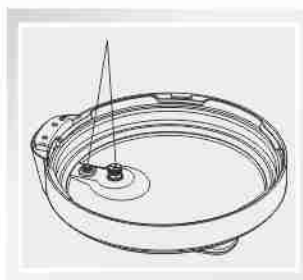

- Make sure all components fix well in Lid before using.



## 6. Troubleshooting

Please use this chart to troubleshoot common problems using Primada Speedy Refine Cooker

No.	Malfunction	Possible causes	Solutions
1	Difficulty in closing the lid	Seal Belt is not properly fitted	Fit in the Seal Belt properly
		Floating valve stuck on the bar	Push the bar lightly
2	Difficulty in opening the lid	Floating Valve has not sunk	Spank the cooker several times to let the valve down in place.
3	Steam leaking out around the lid	Seal Belt is not in place	Fit in the Seal Belt
		Dirty Seal Belt	Clean the Seal Belt
		Damaged Seal Belt	Replace the Seal Belt
		Lid is not closed tightly	Close the lid according to the instructions
4	Steam leakage from the Floating Valve	Dirty Seal Ring for Floating Valve	Clean the Seal Ring for Floating valve
		Damaged Seal Ring For Floating Valve	Replace the Seal Ring for Floating Valve
5	Floating Valve is not rising up	The amount of food and water is lower than the minimum level	Determine the amount of food according to the instructions
		Steam leakage around the lid or from Pressure Limiting Valve	Send the cooker to Service center for checking purposes

## **Pro Logic International Limited**

[www.primada.com.hk](http://www.primada.com.hk)

 (852) 2365 0655 |  [info@iplushome.com](mailto:info@iplushome.com)